

Optimyst® Revive

Model
ABN15-RGB-AM

Installation and User's Guide



We value your feedback!

Your input helps to create even better products and experiences.

Share the warmth and leave a review.

[dimplex.com/sharethewarmth](https://www.dimplex.com/sharethewarmth)

 YouTube @DimplexNorthAmerica

IMPORTANT SAFETY INFORMATION:

Read this manual first before attempting to install or use this electric fireplace. Always comply with the warnings and safety instructions contained in this manual to prevent personal injury or property damage.

To view the full line of Dimplex products, visit www.dimplex.com

Table of Contents

Registration	3
 IMPORTANT INSTRUCTIONS	4
Technical Specifications	6
Electrical Rating	6
Product Dimensions	6
Installation	7
Optimyst components	7
Water quality	7
Fresh Air Inlets	7
Operation	12
General Operation	12
Remote Control Operation	13
Flame Connect Mobile App	16
Resetting the Temperature Cutoff Switch	16
Refilling the water tank	16
Maintenance	17
Cleaning	17
Transducer Replacement	17
Servicing	17
Remote Control Battery Replacement	17
Troubleshooting	18
Wiring Diagram	20
Warranty	21

Conventions used in this manual:

NOTE:

Procedures and techniques that are considered important enough to emphasize.

CAUTION:



Procedures and techniques which, if not carefully followed, will result in damage to the equipment.

WARNING:



Procedures and techniques which, if not carefully followed, will expose the user to the risk of fire, serious injury, or death.

Registration



REGISTER YOUR PRODUCT ONLINE

www.dimplex.com/register

Please record your model and serial numbers for future reference.

Model _____

Serial Number _____

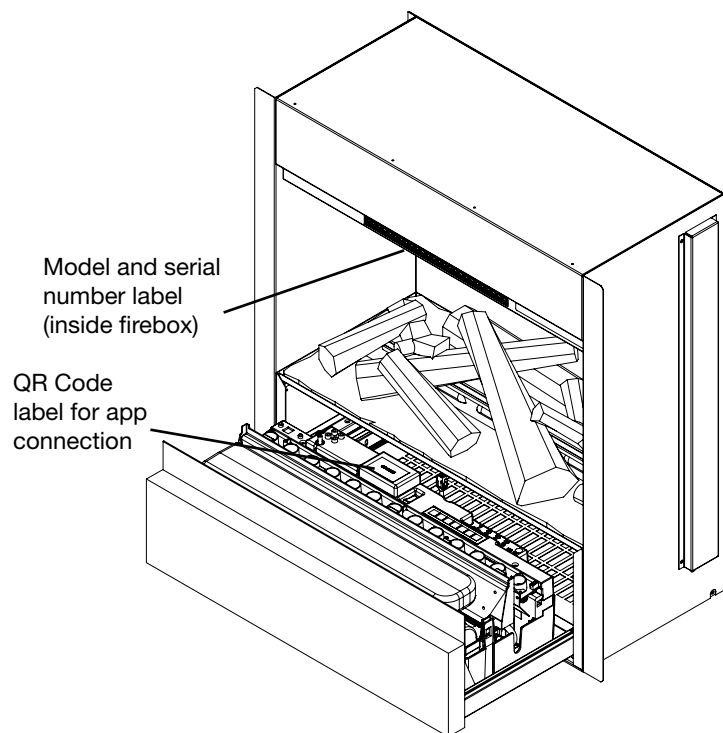

NO NEED TO RETURN TO THE STORE

If you have questions regarding the operation of this product or if you require service, before returning this product to the place of purchase.

For technical support, contact us at:



www.dimplex.com/support

or



Toll-Free 1-888-346-7539

Please have your model number and product serial number ready.

IMPORTANT INSTRUCTIONS

When using any electrical appliance, basic precautions should always be followed to reduce the risk of fire, electric shock, and injury to persons. These precautions include:

- ① Read all instructions before using this electric fireplace.
- ② This fireplace is hot when in use. To avoid burns, do not let bare skin touch hot surfaces. The trim around the heater outlet becomes hot during heater operation.
-  **DANGER:** High temperatures may be generated under certain abnormal conditions. Do not partially or fully cover or obstruct the front of the fireplace.
- ③ Extreme caution is necessary when the fireplace is used by or near children or people with disabilities and whenever the fireplace is left operating and unattended.
- ④ Always turn off the fireplace when it is not in use.
- ⑤ Do not operate the fireplace after it malfunctions, has been dropped, or damaged in any manner. Disconnect power at the service panel and have the fireplace inspected by a reputable electrician before using.
- ⑥ Do not operate any unit with a damaged cord or if the heater has malfunctioned, or if the heater has been dropped or damaged in any manner, contact Glen Dimplex Americas Technical Service at 1-888-346-7539.
- ⑦ Do not use this fireplace outdoors.
- ⑧ Never locate the fireplace where it may fall into a bathtub or other water container.

- ⑨ To disconnect the heater, turn the unit off with the controls and turn off the power to the heater circuit at the main disconnect panel.
- ⑩ Do not insert or allow foreign objects to enter any ventilation or exhaust opening as this may cause an electric shock, fire, or damage to the fireplace.
- ⑪ To prevent a possible fire, do not block air intakes or exhaust in any manner.
- ⑫ All electrical heaters have hot and arcing or sparking parts inside. Do not use it in areas where gasoline, paint, or flammable liquids are used or stored.
- ⑬ Do not modify this fireplace. Use it only as described in this manual. Any other use may cause fire, electric shock, or injury to persons.
- ⑭ Always use a certified electrician should new circuits or outlets be required.
- ⑮ Always use properly grounded, fused and polarized outlets.
- ⑯ Disconnect all power coming to the fireplace at the main service panel before performing any cleaning, maintenance, or relocation of the unit.
- ⑰ When transporting or storing the fireplace, keep it in a dry place, free from excessive vibration, and store to avoid damage.
- ⑱ Regular cleaning and maintenance is required to ensure safe and correct operation.

! NOTE: Changes or modifications not expressly approved by the party responsible for compliance could void user's authority to operate the equipment.

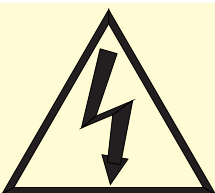

CAUTION
RISK OF ELECTRIC SHOCK
DO NOT OPEN
NO USER-SERVICEABLE PARTS INSIDE



IMPORTANT INSTRUCTIONS

FCC Compliance

⚠ CAUTION: This unit has been tested and found to comply with the limits for Class B digital device, pursuant to part 15 of the FCC Rules. These limits are designed to provide reasonable protection against harmful interference in a residential installation. This unit generates, uses and can radiate radio frequency energy and, if not installed and used in accordance with the instructions, may cause harmful interference to radio or television reception, which can be determined by turning the unit OFF and ON, the user is encouraged to try to correct the interference by one or more of the following measures:

Reorient or relocate the receiving antenna.

Increase the separation between the unit and the receiver.

Connect the unit into an outlet on a circuit different from that to which the receiver is connected.

Consult the dealer or an experienced radio/TV technician for help.

This unit complies with Part 15 of the FCC Rules. Operation is subject to the following two conditions:

(1) This unit may not cause harmful interference, and (2) this unit must accept any interference received, including interference that may cause undesired operation.

⚠ FCC CAUTION: Any changes or modifications not expressly approved by the party responsible for compliance could void the user's authority to operate this equipment.

Frequency band(s) this product operates in: 2.4GHz

Maximum radio-frequency power transmitter in the frequency band(s) this product operates in: 2.71dBm

⚠ WARNING: This product can expose you to chemicals including nickel which is known to the State of California to cause cancer. For more information, visit www.P65Warnings.ca.gov

Conventions used in this manual:

! NOTE: Procedures and techniques that are considered important enough to emphasize.

⚠ CAUTION: Procedures and techniques which, if not carefully followed, will result in damage to the equipment.

⚠ WARNING: Procedures and techniques which, if not carefully followed, will expose the user to the risk of fire, serious injury, or death.

SAVE THESE INSTRUCTIONS

Technical Specifications

Electrical Rating

Voltage: 120 V (3-Wire)

Power: 1250 W

UL Listing

File Number: E71416



Model Reference		
500003863	ABN15-RGB-AM	6914220100

Product Dimensions

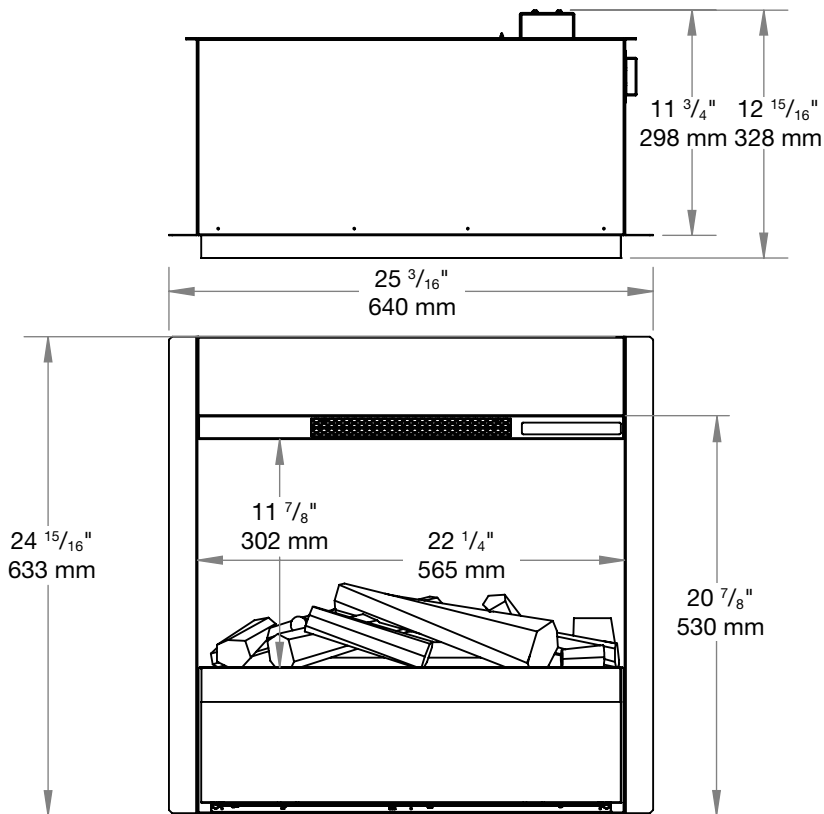

Installation

Optimyst components

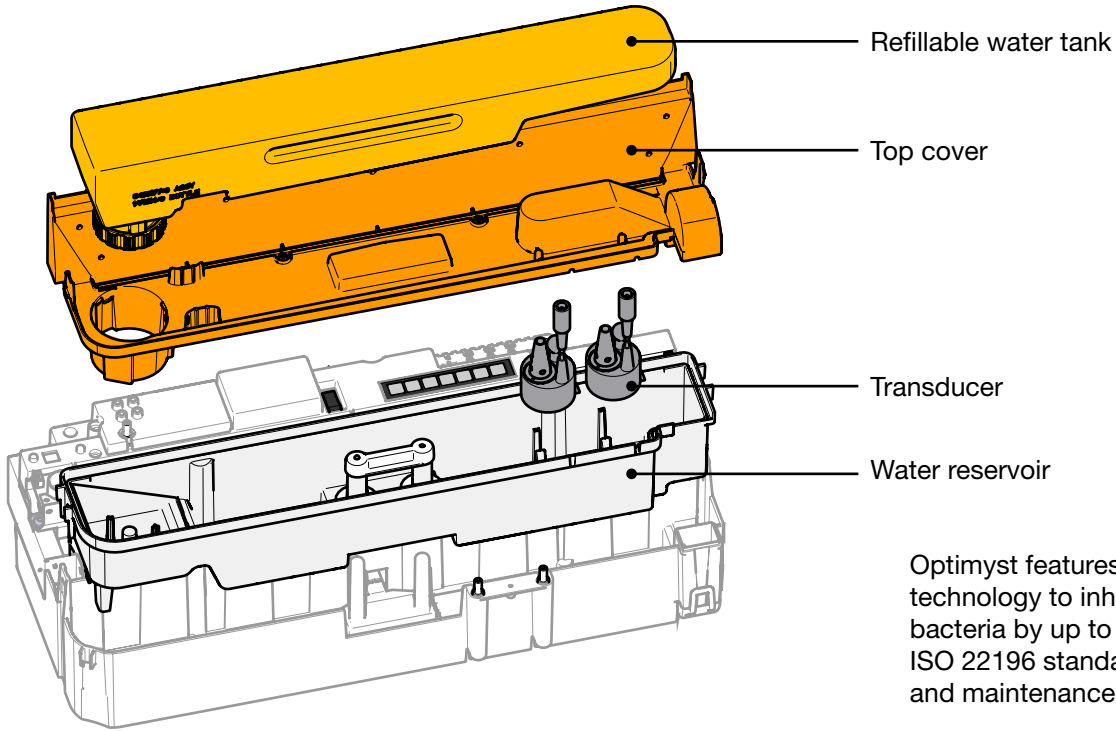

Optimyst features antimicrobial technology to inhibit the growth of bacteria by up to 99.99% (tested to ISO 22196 standard.) Regular cleaning and maintenance is required.

Water quality

- Normal clean tap water should be used.
- In areas with hard water, a water softener is recommended. More frequent cleaning and maintenance may be required.
- Unfiltered water supplied from a well or any other unmonitored supply is not recommended.
- Do not drink the water from the water reservoir or water tank.

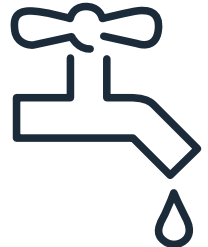

Fresh Air Inlets

⚠ CAUTION: Obstructing the fresh air inlet will result in poor flame performance and damage to the fireplace.

- There is an air inlet under the drawer that must not be obstructed.
- An additional fresh air inlet of 16 in² (100 cm²) that allows the air path to reach the underside of the unit is recommended for optimal flame if the installation permits.
- If using a grille, ensure the covered area has a larger opening to compensate.

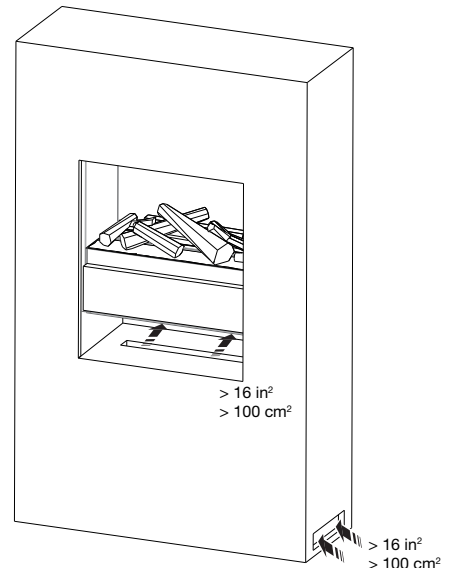

Installation

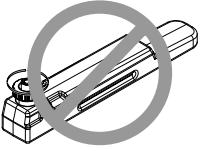

CAUTION: Do not put water in the unit until it is secured

1 Prepare enclosure

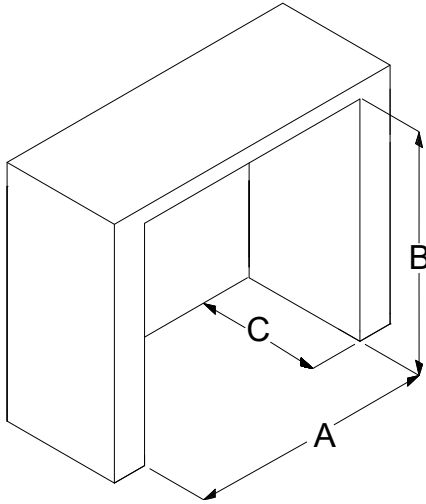

This product can be built into a wall, surround or structure. Refer to the minimum opening dimensions below.

Do not obstruct the gap under the drawer, as this air intake is essential for product operation.

CAUTION: Blocking the air intake will result in poor flame performance and damage to the fireplace.

Minimum opening dimensions		
A	B	C
25 1/4"	25"	12"

Air currents

When determining a location for the product, ensure that the unit will not be susceptible to drafts, vents, ceiling fans and other air currents. Similar to a candle, large movements of air will affect the unit's ability to create and maintain the flame effect.



Installation in a fireplace opening

If fitting this product in an existing fireplace opening, the chimney should be professional cleaned and blocked off for safe and efficient operation.



Installation

2 Connect power supply

⚠ WARNING: Use the appropriate wire to meet local and national electrical codes for rated power consumption.

⚠ WARNING: The installation of the electric fireplace must comply with the applicable Local and/or National Electrical Codes and utility requirements.

⚠ WARNING: This heater is not intended for use with an extension cord. Plug the cord directly into an appropriate grounded wall receptacle.

⚠ CAUTION: A dedicated, properly fused 15 Amp circuit is recommended, rated for 120 V. A dedicated circuit will be required if, after installation, the circuit breaker trips or fuse blows on a regular basis when the heater is operating. Additional appliances on the same circuit may exceed the current rating of the circuit breaker.

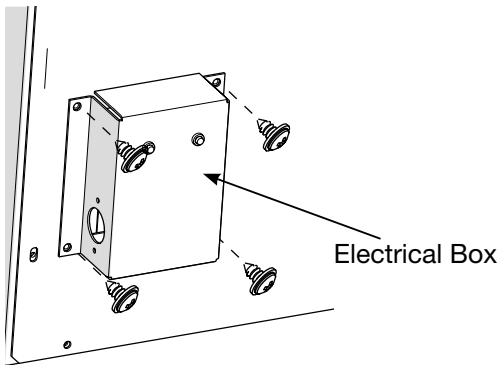

1. Remove the screws that secure the electrical box.
 - If using the power cord, proceed to step 3, following the diagram for 120 V wiring.
2. Secure a 1/2" (1.3 cm) approved strain relief on the electrical box and route the wires through it.
3. Complete the wiring according to the chosen installation. Ensure all wire connections are tight.
4. Secure the electrical box.

120 V Installation (hardwired or power cord)

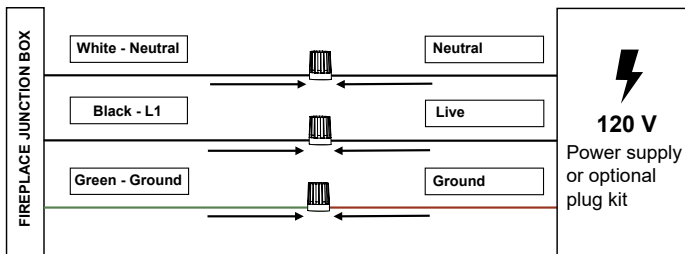

Installation

3 Secure the firebox

⚠ CAUTION: Ensure the firebox is level before securing it.

⚠ CAUTION: Wood screws are included. Make sure to use suitable hardware based on the material you're installing into.

Once the product is level, and in the desired position, it must be secured to ensure it can't tip over when the drawer is opened. There are two options to secure the firebox.

L-Brackets:

1. Use the black screws to fix the L-brackets to the firebox.
2. Use appropriate hardware to secure the bracket to the base.

Under the fuel bed:

1. Unscrew the fuel bed and carefully lift off to remove. The fuel bed should be lifted by holding the metal tray the logs are fixed on, not by lifting the top logs as this could damage them.
2. Using fixing screw pack provided, secure the product through the fixing holes in the base.
3. Carefully place the fuel bed back in position, lifting by the metal tray and secure it with the screws.

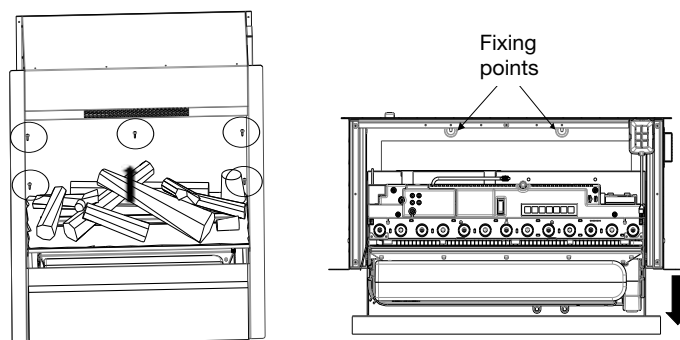
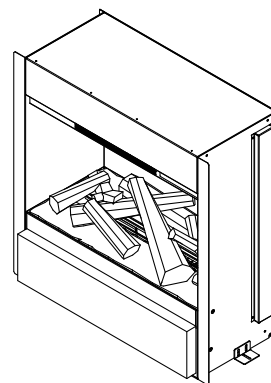

4 Fill the water tank

1. Open the drawer and remove the water tank from its location on top of the water reservoir.
2. The tank should be filled with clean tap water only - Refer to Water Quality (page 7) for more details.
3. Close the drawer.

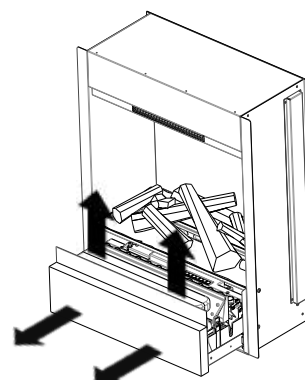

Installation

5 Install batteries in remote control

The remote control is supplied with two AA batteries in a bag. Lift off the battery cover on the back of the remote control and insert the batteries taking note of the polarity.

6 Customize flame effect

Install either the spacers or the slotted inserts, depending on the desired appearance of the flame effect.

Slotted inserts

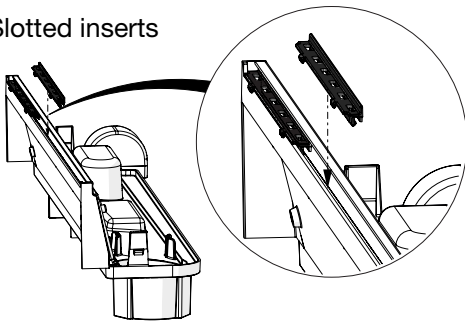

To use the slotted inserts, insert them into the nozzle. Three slotted inserts fit into each nozzle.

Spacers

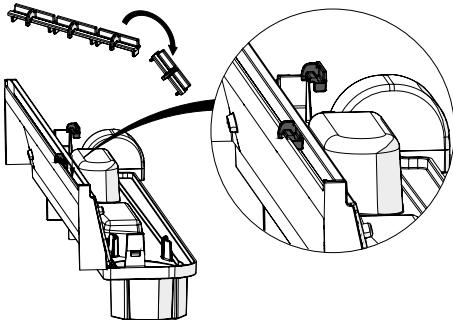

To use the spacers, first break them along the break line. Insert them into the nozzle and slide them as desired.

It is recommended to place a spacer directly underneath any log that crosses through the flame to reduce condensation.

Operation

General Operation

⚠ WARNING: This electric firebox must be properly installed before it is used.

! NOTE: After a power interruption the fireplace will return to Standby mode and retain the previously used settings.

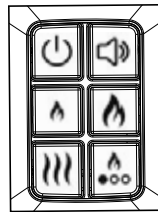
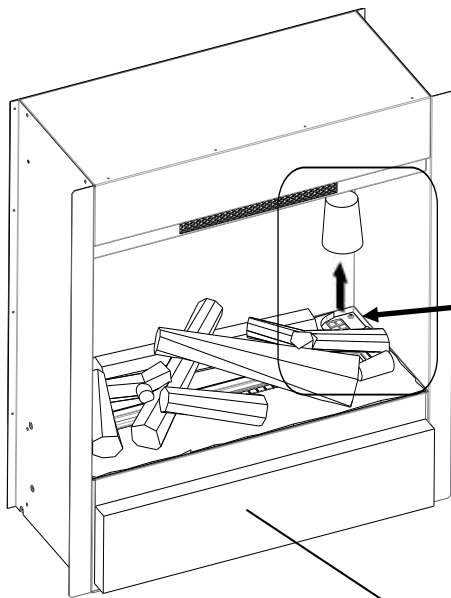

Manual controls

Follow remote control instructions to operate

Power switch

Note: This switch must be in the 'ON' (I) position for each appliance to operate

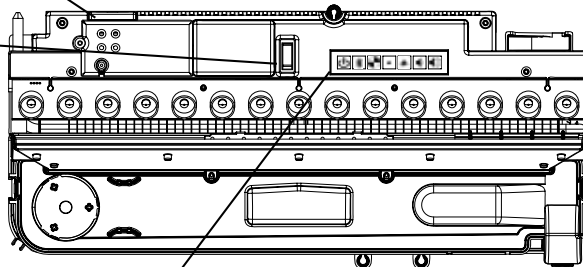
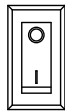

Control panel:

Open the drawer to access the control panel.

Remote Control Operation

! NOTE: After a power interruption the fireplace will return to Standby mode and retain the previously used settings.

- 1 Display Screen
- 2 'Menu' Button
- 3 'Back' Button
- 4 'Advance' Button(ADV)
- 5 'Up and Down' Arrows
- 6 'Enter' Button (Press to Activate the Remote)

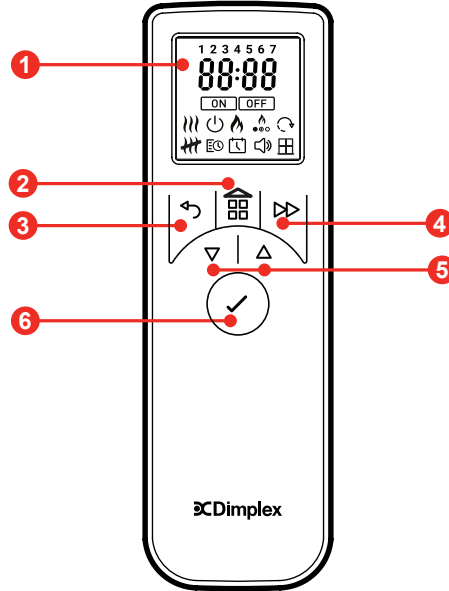

Navigation

To use the functions, press menu and use the ▽ or ▲ arrows until the desired selection is flashing. Press ⏹ to confirm selection. Use the ▽ or ▲ arrows to adjust the setting and press ⏹ to select.

Sleep Mode

The remote control display turns off when not in use to conserve power. To activate the remote, press ⏹. There is a small delay before the screen turns on.

Standby

























When it is in standby, the remote will display OFF. Press Enter to turn it on. When the unit is on, the remote will display ON. Use the arrows to select the standby icon to put it in standby.

Pairing the remote control









Your remote control is already paired with your product from the factory. If it ever disconnects or you get a new remote, it will need to be paired again. To pair the remote to the fireplace:





1. Open the drawer and press the rocker switch to the on (I) position. You should hear an audible beep.
2. Press and hold ⏹ until PAIR appears on the display
3. Bring the remote control close to the product where the receiver is.
4. The product will start to beep and blink
5. Press ⏹ to complete the pairing process. The product will go into standby mode.

Operation

	Standby	<p>Toggles standby on and off. There is a 45-second warm up sequence after pressing this button before the flame starts.</p>
	Flame Intensity	<p>Adjust the flame height of the product for optimal performance. There are six levels of flame intensity, Note that more flame/mist is often needed after prolonged use, so don't start at the maximum level upon purchase. Choose the right flame height for the best results and a longer product lifespan.</p> <p>Press  or  on manual controls to desired Flame intensity</p> <p>On remote, select  and adjust as needed.</p> <p>Please give the flame generator time to react to the changes you make.</p>
	Flame Theme	<p>On remote control, select  and select the Flame theme.</p> <p>On manual controls press  repeatedly to cycle through the Flame themes.</p> <ul style="list-style-type: none"> 1 - Natural Flame 2 - Blue 3 - Violet 4 - Red 5 - Aquamarine 6 - Prism Mode - the flames will cycle through the different colours.
	Volume and crackle sound	<p>Select the volume of the crackle sound from the five volume settings or to turn off the crackle sound.</p> <p>For authenticity you can add the sound of crackling logs to the flame effect. Select the  icon on the remote to adjust the sound level by pressing ∇ or Δ followed by ENTER to select. On the manual controls the  button turns the sound on/off.</p>
	Heat On / Manual Mode	<p>Press to turn heat on/off on manual controls.</p> <p>With remote, after selecting , use ∇ or Δ adjust to the desired room temperature. Note the default temperature setting is 21°C and the maximum temperature set point on the product is 30°C. Press enter to confirm,</p>
	Heat Off (Remote)	<p>To turn Heat OFF, Press the Menu  or Back  button, then use ∇ or Δ to highlight the  symbol and press Enter to select.</p>
	Date/Time (Remote)	<p>Date and time must be set up prior to use or after changing the batteries. To set the date and time on the remote:</p> <ol style="list-style-type: none"> 1. Press Enter when the  is blinking 2. Press ∇ and Δ to set the Hour, press  <p>Note: this product uses as 24-hour clock.</p> <ol style="list-style-type: none"> 3. Press ∇ and Δ to set the Minutes, press  4. Press ∇ and Δ to set the Day, press  5. Press ∇ and Δ to set the Month, press  6. Press ∇ and Δ to set the Year, press  7. Press ∇ and Δ to select ON/OFF for the Daylight saving time, press Enter to confirm and returns to home screen.

Operation

	<p style="text-align: center;">Timer Schedule (Remote)</p>	<p>This features will allow the product to turn on or off automatically at scheduled times. Four times slots are available throughout the day and these can be customised for each day of the week.</p> <p>To toggle the the timer schedule on or off, navigate to . Select <input type="checkbox"/> ON or <input type="checkbox"/> OFF.</p> <p>To re-programme the factory default programs:</p> <ol style="list-style-type: none"> Navigate to . Select EDIT. Press . <p>*Days of the weeks are now displayed at the top of the screen* Day 1 = Monday, Day 2 = Tuesday, Day 3 = Wednesday, Day 4 = Thursday, Day 5 = Friday, Day 6 = Saturday, Day 7 = Sunday</p> <ol style="list-style-type: none"> Press Δ to navigate to the desired day and press . <p>P1 will be displayed on screen</p> <ol style="list-style-type: none"> Press Enter to select P1, or press Δ to navigate to P2, P3 or P4. Press . <p>ON will be displayed</p> <ol style="list-style-type: none"> Use ∇ or Δ to adjust the ON Hour time, press . Use ∇ or Δ to adjust the ON Minute time, press . Use ∇ or Δ to adjust the Temperature setting, press . <p>OFF will be displayed</p> <ol style="list-style-type: none"> Press ∇ or Δ to adjust the OFF Hour time, press Enter to Confirm Press ∇ or Δ to adjust the OFF Minute time, press Enter to Confirm Press Enter to modify Programme P2, follow steps 5-12, Press Δ to skip to P3 Press Enter to modify Programme P3, follow steps 5-12, Press Δ to skip to P4 Press Enter to modify Programme P4, follow steps 5-12 <p>To copy newly programmed P1-P4 heating programmes to other days, press and hold ADV button COPY will be displayed then navigate UP/DOWN buttons to other days, while the day flashing press and hold ENTER button to paste, PASTE will be displayed to confirm the setting.</p>
---	---	--

Advanced functions		
<p>To access the functions below, press and hold the Menu  and Advance button \triangleright at same time for 3 seconds to access the Advance menu options.</p> <p>Use the ∇ or Δ unit you see the desired menu & press ENTER to select.</p> <p>Note Sb and  features are not enabled for this product</p>		
<p>rb</p>	<p style="text-align: center;">Runback Timer</p>	<p>The product will go to standby after designated period.</p> <p>Select ON using ∇ or Δ (will be flashing) and Enter to go to time menu.</p> <p>Press ∇ or Δ to highlight desired preset time period (30min, 1hr, 1.5hr, 2hr, 4hr, 8hr) and ENTER to select.</p> <p>Will highlight rb on screen when active.</p>
<p>fp</p>	<p style="text-align: center;">Frost Protection</p>	<p>Frost protect mode prevents the room from freezing. The heater will turn on if the room temperature drops below 7°C.</p> <p>Will indicate fp on the screen when active.</p>
<p>0C 0F</p>	<p style="text-align: center;">Temperature Unit Display</p>	<p>User can change the Units of the temperature (°C and °F). Use ∇ or Δ to select and  to confirm.</p>
	<p style="text-align: center;">Adaptive Start</p>	<p>This feature learns how long it takes to heat the room to the set temperature. When it is active, the heater will start heating ahead of schedule to achieve the desired temperature at the scheduled time. The Adaptive Start function will automatically activate when you use the scheduled programs.</p>

Flame Connect Mobile App

For even more features, the fireplace can be controlled using the Flame Connect App for mobile devices. This is available to download to your device from Google Play or Apple App stores. Follow the on screen instructions for set-up. The product QR code can be found on the original owner's manual provided with the fireplace or in the drawer of the fireplace (location shown on page 3).

! **NOTE:** The app allows your device to be used as a bluetooth remote control, but not through a Wi-Fi network. The fireplace will not operate using the remote control when the app is open on a mobile device.



Resetting the Temperature Cutoff Switch

Should the heater overheat, a manual limit cut-out will turn the unit off and it will not come back on without being reset. It can be reset by turning the unit off from the main ON/OFF switch or at the main disconnect panel and waiting 10 minutes before turning the unit back on.

⚠ **CAUTION:** If you need to continuously reset the heater, turn the unit off at the main disconnect panel and call technical support at: 1-888-346-7539.

Refilling the water tank

The LEDs will flash and beep twice when the water tank is almost empty. After 15 minutes, it will beep once and only the fuel bed will remain illuminated while in low water mode. To refill the water tank:

1. Open the drawer and remove the water tank.
2. Refill the water tank using filtered/decalcified water only.
3. The tank can then be replaced on top of the water reservoir.
4. If the product was not switched into stand-by mode after experiencing low later, the product will restart automatically after about 20 seconds of refilling.

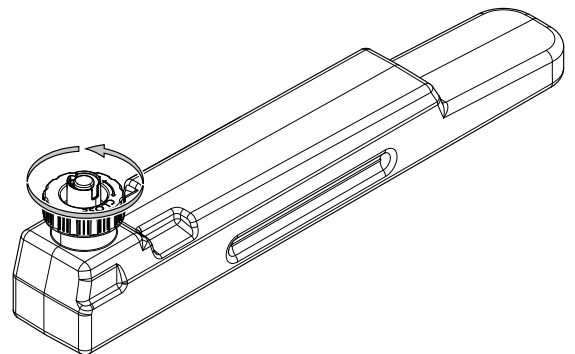

Maintenance

- ⚠ WARNING:** Disconnect power and allow element to cool before attempting any maintenance or cleaning to reduce the risk of fire, electric shock or damage to persons.
- ⚠ CAUTION:** If you need to move the unit ensure that all of the components that contain water have been emptied before relocating.
- ! NOTE:** If you do not intend on using the unit for longer than 2 weeks, empty and drain the unit of water, and dry all of the wet components.

Cleaning

It is required that the top cover, water reservoir, refillable water container, and transducer are cleaned with soap and water on a regular basis, **at a minimum once per month**. More frequent cleaning may be required depending on water quality.

⚠ CAUTION: Do not put plastic components in the dishwasher.

The air filters can be removed and gently rinsed with water to clean and dried on a towel before reinstalling. Reinstall the filter so that the coarse black side of the filter is facing the back of the unit.

Use only a damp cloth to clean the surfaces of the unit. Do not use abrasive cleaners

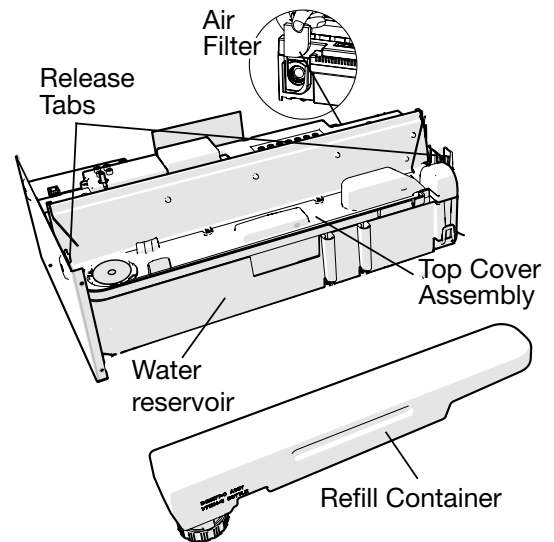

Transducer Replacement

After prolonged use, the ability for the unit to produce mist may become reduced. If cleaning does not improve the performance of the flame effect, replacement of the transducer may be required. This unit comes with replacement transducers. Additional transducers may be purchased at www.dimplex.com/replacement-parts (9601210100RP).

- ! NOTE:** To remove the transducer, release the retaining tab in the water reservoir and remove transducer.

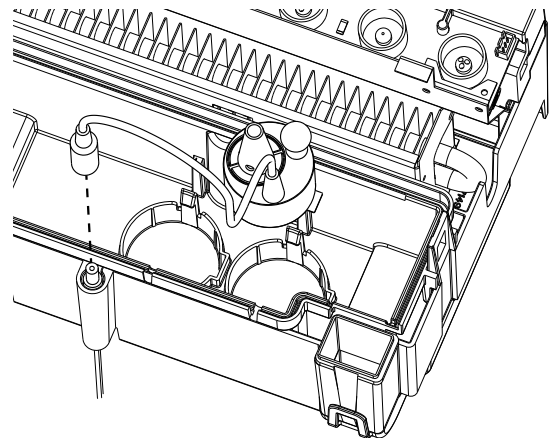

Servicing

Except for installation and cleaning described in this manual, an authorized service representative should perform any other servicing.

Remote Control Battery Replacement

To replace the batteries:

1. Remove battery cover of the remote.
2. Correctly install two AA batteries in the battery holder.
3. Secure the battery cover.



Batteries must be recycled or disposed of properly. Check with your Local Authority or Retailer for recycling advice in your area.

Troubleshooting

For more troubleshooting, consult the service manual which can be found at www.dimplex.com/customer_support/technical_and_troubleshooting

Problem	Cause	Solution
Fireplace does not turn on with the onboard controls	Power switch is not on	Ensure the power switch is on.
	No incoming power	Ensure unit is wired correctly. Check main disconnect panel.
	Bluetooth receiver connection is loose	Check connection to the receiver
Fireplace does not respond to commands given from the remote control	The batteries in the remote control are dead or installed incorrectly.	Replace remote control batteries. Ensure batteries are installed correctly.
	Remote control not paired to fireplace.	Follow directions for pairing the remote in the Operation section.
	Remote out of range	Ensure the remote is within 16' (5 m) of the fireplace
	Bluetooth receiver connection is loose	Check connection to the receiver
Fireplace beeps once and tethered controller light is on, but no other functions work	Power supply brick is unplugged	Verify the connection to and from the power supply brick.
Heater is on, but there is no heat	The temperature setpoint is below the ambient temperature.	Using the remote or the app, increase the temperature setting, so that it is above the ambient temperature.
Circuit breaker trips or fuse blows when unit is turned on	Improper circuit current rating	Install unit on a dedicated minimum 15 amp circuit.
Product will not operate. The LED fuel bed only operates.	There is a delay after pressing  .	There is a 45-second warm up sequence before the flame starts
	Low water reading	Refill the water tank(s) of the product. See "Filling the Water Tanks" above.
	Product is not level	Ensure the product is level by checking the on-board level.
LEDs blink twice and product beeps twice	Product is approaching low water	Refill the water tank(s) of the product. See "Filling the Water Tanks" above.
Product will not operate. LEDs continuously blink twice every 8 seconds	Low water reading	Refill the water tank(s) of the product. See "Filling the Water Tanks" above.
Product will not operate. LEDs continuously blink three times every 8 seconds	Water fill error	Ensure there are no leaks in the water reservoir.
		Ensure that the floats are moving freely within the water reservoir.
		Ensure the product is level.
Product will not operate. LEDs continuously blink four times every 8 seconds	Fill time from min to max level has been exceeded	Refill the water tank(s) of the product. See "Filling the Water Tanks" above.
Product will not operate. LEDs continuously blink once every 8 seconds	Overflow Detection	Switch off the product and the water supply. Contact your dealer for assistance.

Troubleshooting

Problem	Cause	Solution
Little or no mist generation	Transducer not operating correctly	Check operation of transducer
	Transducer is dirty	Clean water reservoir and transducer
	Transducer is not sitting correctly in water reservoir	Switch off product, take nozzle off water reservoir and ensure transducer is fitted in water reservoir correctly
	Fan is obstructed or blocked	Remove air filter and clean. Ensure it is placed back in product correctly.
	Nozzle is not on water reservoir correctly	Ensure Nozzle is sitting on water reservoir correctly
	Nozzle is blocked	Clean water reservoir, transducer and nozzle
The flame effect has too much smoke.	Flame effect setting is too high	Turn down the flame effect. Give the product time to adjust to the new setting

Wiring Diagram

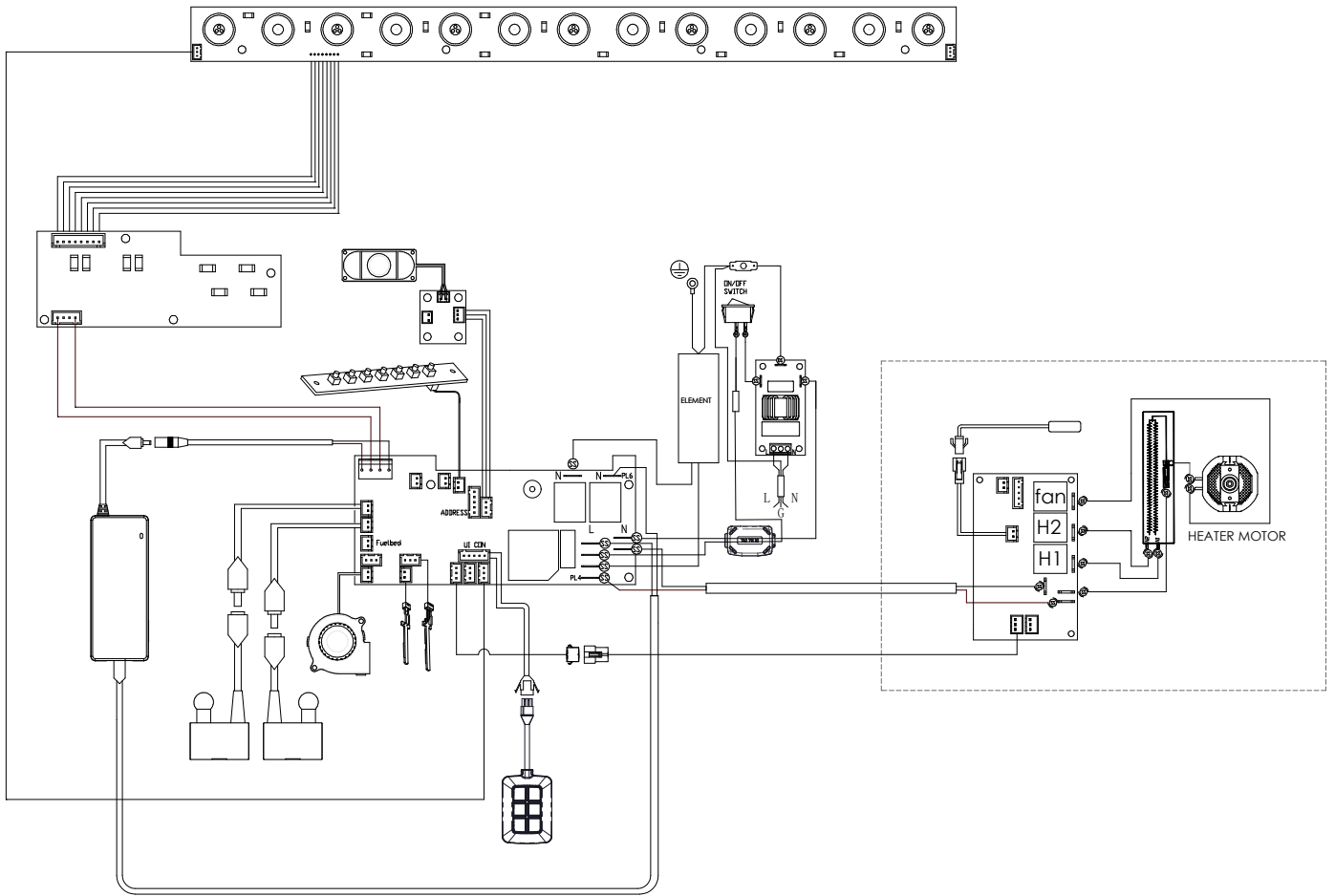

Warranty

OPTI-MYST REVIVE™ 2-YEAR LIMITED WARRANTY

Section 1 Products to which this Limited Warranty Applies

This Limited Warranty applies to your newly purchased Dimplex electric fireplace with model number ABN15-RGB-AM.

This Limited Warranty applies only to purchases made in any province of Canada except for Yukon Territory, Nunavut, or Northwest Territories or in any of the 50 States of the USA and the District of Columbia except for Hawaii and Alaska. This Limited Warranty applies to the original purchaser of the product only and is not transferable.

Section 2 Products excluded from this Limited Warranty

Products purchased in Yukon Territory, Nunavut, Northwest Territories, Hawaii, or Alaska are not covered by this Limited Warranty. Products purchased in these States, Provinces, or Territories are sold AS IS without Warranty or condition of any kind including, without limitation, any implied warranties or conditions of merchantability or fitness for a particular purpose. The entire risk of as to the quality and performance of the products is with the purchaser. In the event of a defect, the purchaser assumes the entire cost of all necessary servicing or repair.

Section 3 What this Limited Warranty covers and for How Long

Opti-Myst Revive™ (ABN15-RGB-AM) excluding trims and accessory packages are covered by this Limited Warranty, have been tested and inspected prior to shipment and, subject to the provisions of this Warranty, Glen Dimplex Americas Ltd. (herein called Glen Dimplex Americas) warrants such products to be free from defects in material and workmanship for a period of 2 years from the date of the first purchase of such products. The 2-year Limited Warranty entitles the purchaser to On-site or In-home Warranty Services. Accordingly, Glen Dimplex Americas will be responsible for all labor and transportation associated with repairing or replacing the product or part. Exceptions to this are outlined in Section 5. Some jurisdictions do not allow limitations on how long an implied Warranty lasts, so the above limitation may not apply to the purchaser.

Section 4 What this Limited Warranty Does Not Cover

This Limited Warranty does not apply to products that have been repaired (except by Glen Dimplex Americas or its authorized service representatives) or otherwise altered. This Limited Warranty does further not apply to defects resulting from misuse, abuse, accident, neglect, incorrect installation, improper maintenance or handling, or operation with an incorrect power source.

Section 5 How to notify us of a Warranty Concern

Defects must be brought to the attention of Dimplex Customer Service online at dimplex.com/en/contact_us or by telephone at 1-888-346-7539. Please have proof of purchase, catalogue/model and serial numbers available for representatives to assist. **Limited In-home Warranty Services require proof of purchase.

In the event a product or part covered by this Limited Warranty is proven to be defective in material or workmanship during (i) the 2-year Limited Warranty period for products outlined in Section 1, you have the following rights:

- Glen Dimplex Americas will in its sole discretion either

repair or replace such defective product or part without charge. If Glen Dimplex Americas is unable to repair or replace such product or part, or if repair or replacement is not commercially practicable or cannot be timely made, Glen Dimplex Americas may, in lieu of repair or replacement, choose to refund the purchase price for such product or part.

- Limited Warranty service will be performed solely by dealers or service agents of Glen Dimplex Americas authorized to provide Limited Warranty services.
- This 2-year Limited Warranty entitles the purchaser to On-site or In-home Warranty services. Accordingly, Glen Dimplex Americas will be responsible for all labor and transportation associated with repairing or replacing the product or part except as follows: (i) charges which may be levied for travel costs incurred to travel to the purchaser's site where the product is located if the purchaser's site is beyond 30 miles (48 km) from the closest service depot of Glen Dimplex Americas dealer or service agent; and (ii) the purchaser is solely responsible for providing clear access to all serviceable parts of the product.
- Glen Dimplex Americas will not be responsible for, and this Limited Warranty shall not include, any expense incurred for installation or removal of the surrounds (mantels) or trims or any part thereof (or any replacement product or part) including, without limitation, all shipping costs and transportation costs to and from the authorized dealer's or service agent's place of business and all labor costs. Such costs shall be the purchaser's sole responsibility.

Section 6 When Glen Dimplex Americas and its Dealers and Service Agents are not Liable

IN NO EVENT WILL GLEN DIMPLEX AMERICAS, OR ITS DIRECTORS, OFFICERS, OR AGENTS, BE LIABLE TO THE PURCHASER OR ANY THIRD PARTY. WHETHER IN CONTRACT, IN TORT, OR ON ANY OTHER BASIS, FOR ANY INDIRECT, SPECIAL, PUNITIVE, EXEMPLARY, CONSEQUENTIAL, OR INCIDENTAL LOSS, COST, OR DAMAGE ARISING OUT OF OR IN CONNECTION WITH THE SALE, MAINTENANCE, USE, OR INABILITY TO USE THE PRODUCT, EVEN IF GLEN DIMPLEX AMERICAS OR ITS DIRECTORS, OFFICERS, OR AGENTS HAVE BEEN ADVISED OF THE POSSIBILITY OF SUCH LOSSES, COSTS OR DAMAGES, OR IF SUCH LOSSES, COSTS, OR DAMAGES ARE FORESEEABLE. IN NO EVENT WILL GLEN DIMPLEX AMERICAS, OR ITS OFFICERS, DIRECTORS, OR AGENTS BE LIABLE FOR ANY DIRECT LOSSES, COSTS, OR DAMAGES THAT EXCEED THE PURCHASE PRICE OF THE PRODUCT. SOME JURISDICTIONS DO NOT ALLOW THE EXCLUSION OR LIMITATION OF INCIDENTAL OR CONSEQUENTIAL DAMAGES, SO THE ABOVE LIMITATION OR EXCLUSION MAY NOT APPLY TO THE PURCHASER.

How State and Provincial law(s) apply

This Limited Warranty gives you specific legal rights, and you may also have other rights which vary from jurisdiction to jurisdiction. The provisions of the United Nations Convention on Contracts for the Sale of Goods shall not apply to this Limited Warranty or the sale of products covered by this Limited Warranty.



Welcome to Flame Connect

Control your electric fireplaces,
from the palm of your hand.



Connect your electric fireplaces

Add as many fireplaces as you like
to the Flame Connect App.



Personalize your product

Change modes and settings on
your fireplace to suit your mood.



Secure your device

Take ownership of a product to prevent
unauthorized access.



NEW! Flame Connect app

Download the Flame Connect app on your mobile device and create an account. With the app you can add an extra level of personalization, such as saving customized mood settings.

For additional information, visit www.flame-connect.com

Available in the App Store and Google Play



1-888-346-7539 | www.dimplex.com

In keeping with our policy of continuous
product improvement, we reserve the
right to make changes without notice.

© 2024 Glen Dimplex Americas